

# GeoArm & GeoLink



## Nearshore Survey Solution

Kraken's GeoArm & GeoLink are stable vessel mounted platforms specifically designed to provide shallow water, nearshore subsea surveys up to 15 m water depth. The mounts deliver the ability to complete nearshore projects effectively and efficiently using the 3D acoustic Sub-Bottom Imager (SBI).

Our hydraulically actuated Sub-Bottom Imager allows surveys within close proximity to port infrastructure. These systems can also keep the SBI parallel to the survey line or cable position whilst the vessel counters currents, minimising downtime.

### UXO Surveys

The SBI is a 3D acoustic survey system which produces a 6 m wide, 5 m deep 3D volume below the seabed, with the ability to detect buried objects within the seabed including boulders, pUXO, debris and infrastructure. Being acoustic, the SBI can detect pUXO anomalies without interference from the as built environment, making it the ideal tool to de-risk nearshore construction projects.

### Cable & Pipeline Surveys

The GeoArm/Link enables cable owners, operators and installation contractors to utilise the same, market leading SBI data along the entirety of the cable, from nearshore to offshore, providing 100% coverage of buried cables whilst remaining operational and maintaining consistent accuracy and baseline position along the cable.

Whether your survey requirements are for a cable depth of burial, UXO harbour survey or identification of buried assets, geohazards or infrastructure survey, the GeoArm/GeoLink will deliver an unmatched solution.

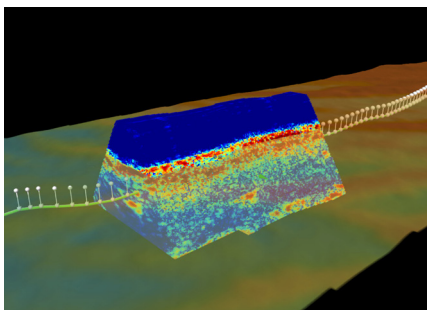

3D volumetric data set - one line gives 6 m swath of coverage at the seabed

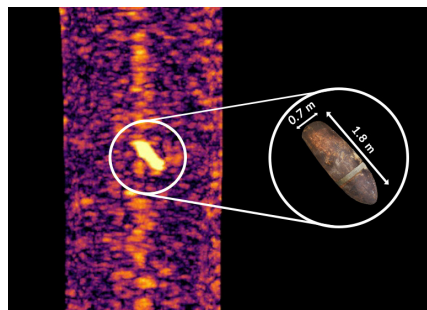

UXO identified 4 m sub-seabed, beyond reach of traditional surveys

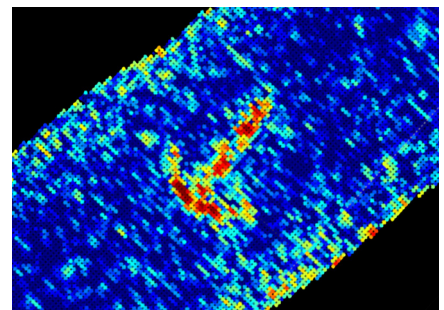

SBI data located buried anchor along with other anomalies/boulders



# GeoArm & GeoLink



GeoArm / GeoLink Specifications	
Operational Depth	3 m to 15 m
Survey Speed	Up to 4 kn
Swath Width	Minimum 5 m
Penetration Depth	5 m
Accuracy	± 10 cm
Survey Height (Off Seabed)	3.5 m ± 0.5 m
Power Requirements	115 VAC, 50/60 Hz
Hydraulic Requirements	2 JIC4 Port @ 1200 psi
Communication Link	1000 Base-T 1 GB Ethernet
ROV Interfaces	Work Class/Lighter ROVs
Data Acquisition Software	SBI Pilot Console
Processing & Visual Software	EIVA NaviModel Producer
Auxiliary Sensors	INS/DVL, Sound Velocity Probe/Depth Sensor



Above: GeoArm

Above: GeoLink

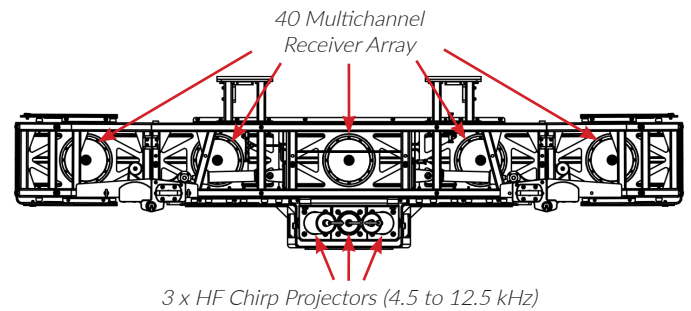

Performance specifications represent maximum sensor values and may vary due to environmental conditions, vehicle stability, and operational specifics.

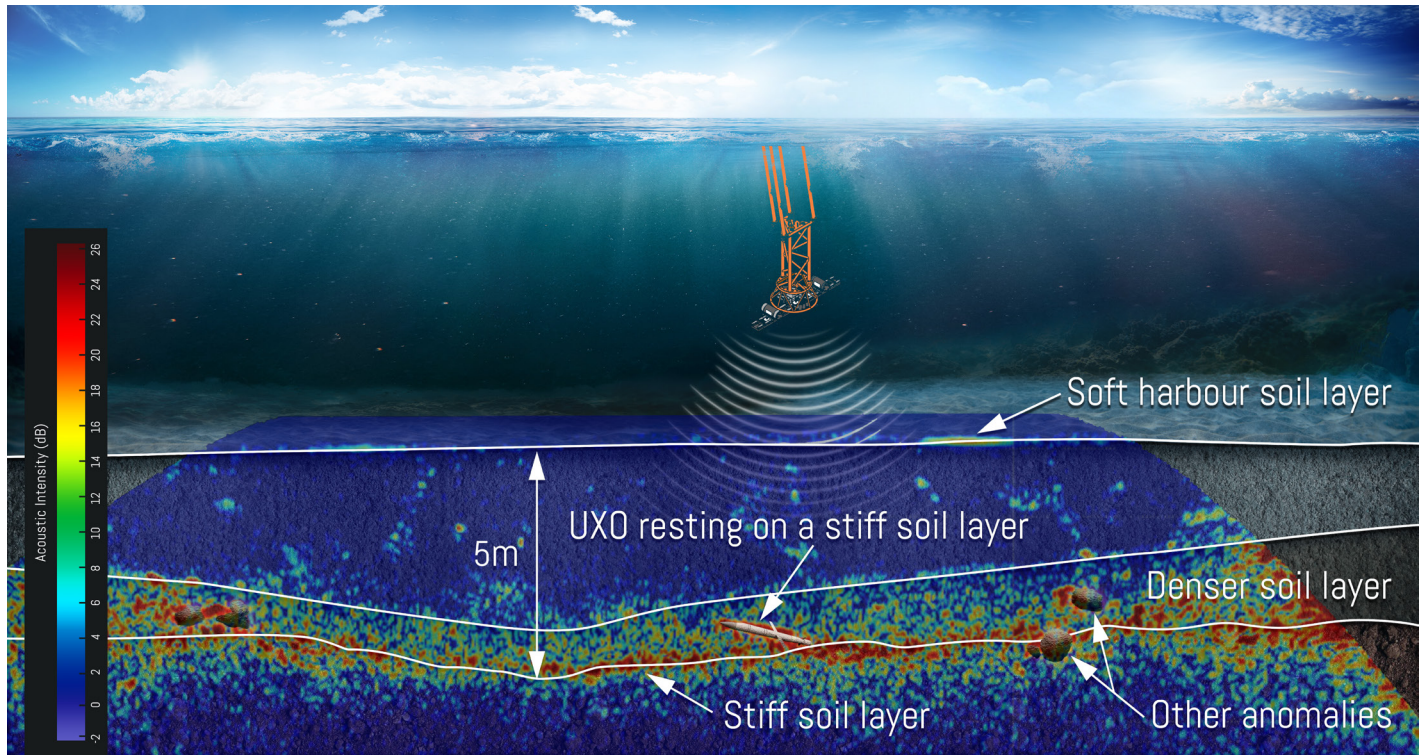

Visual representation of an actual buried UXO, with graphic overlay, located by the GeoLink. Previously undetected by magnetometry and sub-bottom profiler. SBI data imagery as seen in a real-time vertical slice.

