

Acoustic Corer™

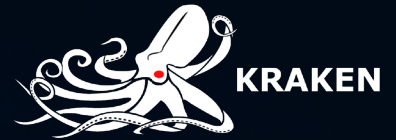

De-Risking Offshore Pile Installations

The Acoustic Corer™ is a subsea surveying technology that interrogates the sub-seabed to optimize offshore installation programs. The Acoustic Corer fills the gap between current geophysical and geotechnical site investigation methods by providing a 3D acoustic core 14 meters in diameter penetrating up to 60 meters into the sub-seabed.

The Acoustic Corer™ (AC) images geohazards such as boulders, gassy soils, and unexploded ordnance (UXO) which can impact the safe and efficient installation of foundations. It also delineates subsea stratigraphy like the top of bedrock, gravel/cobble layers, and dipping slippage in planes/beds while providing soil characterization. The AC is utilised in the offshore renewable energy and oil and gas markets where foundations are being installed in complex seabeds and more detail is required to ensure appropriate foundations are designed and subsequently installed efficiently. The AC specializes in subsea installations, rig relocation (borehole replacement), and excavated drilling centers in the oil and gas sector. The AC can also be used in Marine and Mining Archaeology, identifying marine artifacts, deposit delineation, and nodule detection. The AC provides:

- A comprehensive sub-seabed image below the proposed foundation locations which identifies all buried boulders >0.2 m in diameter
- Identification of geological features, including; changes in lithological properties, shallow faulting, channels and shallow-gas
- Geotechnical context across the foundation footprint and the ability to correlate these properties to 3D geophysics
- Ability to target features of interest for geotechnical sampling and resolve conflict observed in geotechnical samples

All data is visualized live, with preliminary results provided within 24 hours of each locations survey, enabling in-field decision-making. Post-survey data interpretation durations are dependent on the level of scrutiny required, which may include site-wide velocity models, merging of all cores into a single 3D volume, statistical analysis, correlation to existing geotechnical data.

By providing market-leading resolution below the seabed, the AC enables our clients to have full confidence that their foundation installation campaign will remain on schedule and in budget by removing the risk of pile refusals, buckling of foundations or pile slippage.

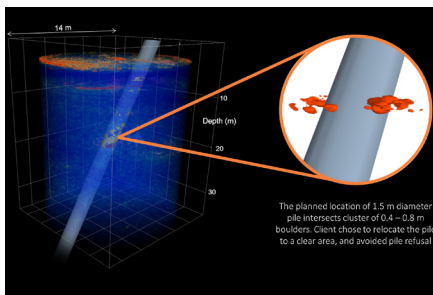
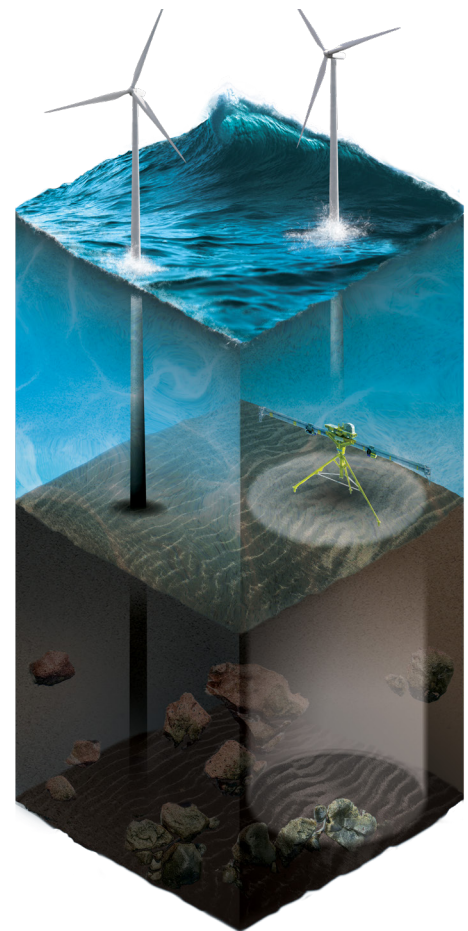

Acoustic Core revealing a cluster of buried boulders in planned pile location

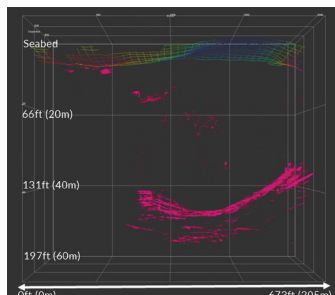

Acoustic Corer data showing linear asset sub-seabed

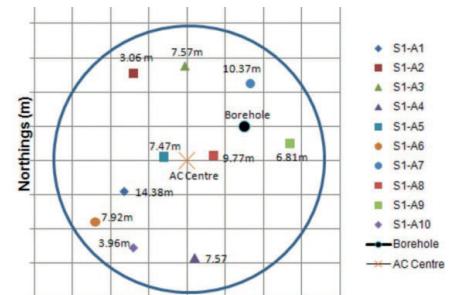

Acoustic Core Geohazard Report - Plan View with boulder diametres

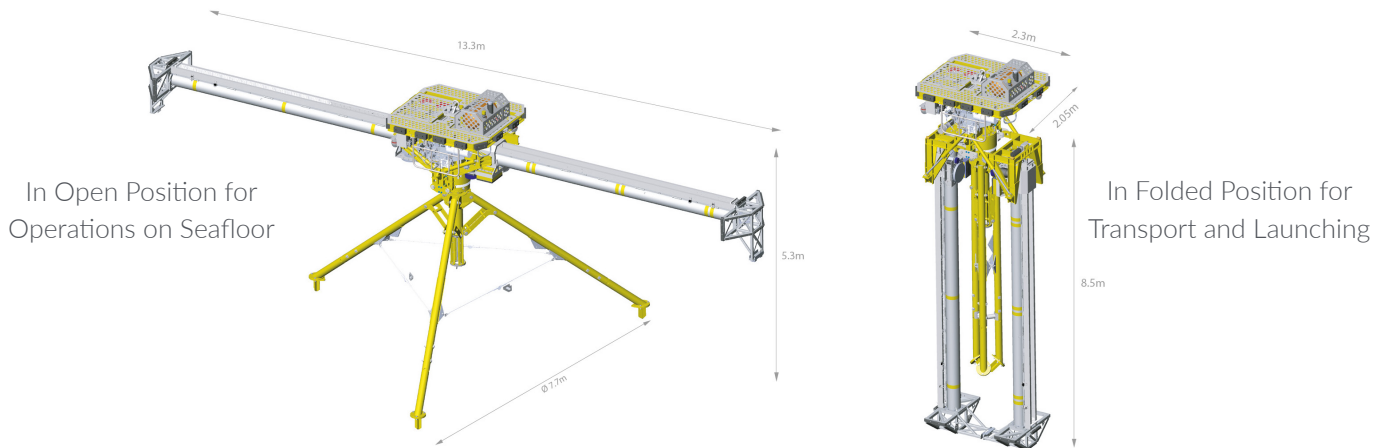

GENERAL SPECIFICATIONS

ITEM	WEIGHT IN AIR (kg)	LENGTH (m)	WIDTH (m)	HEIGHT (m)
Acoustic Corer (folded for transport)	5,500	8.5	2.3	2.05
Acoustic Corer (deployed)	5,500	13.3	2.3*	5.3
ISO 20' Control Van DNV 2.7.1	5,500	6.1	2.4	2.6
ISO 10' Spares Container	4,000	3.1	2.4	2.6
1,500 m Winch & Umbilical	225.7	1.5	1.8	1.5

*boom rotates 180 degrees, requires 13.3 m diameter clearance

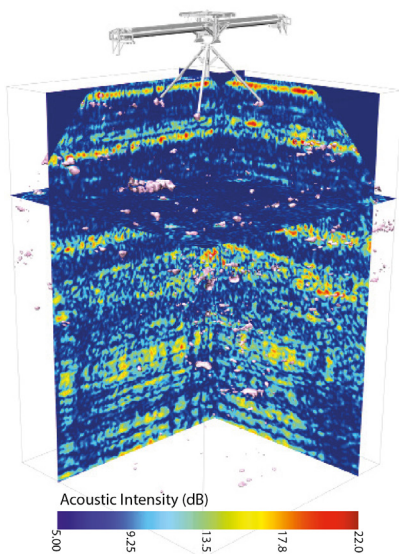

FirstLook™ 3D QC Visualization

OPERATIONAL SUPPORT REQUIREMENTS

- DP 1/2
- 20t crane (heave compensated in waters deeper than 100 m)
- Onboard survey and positioning
- IMCA class 2 ROV support

OPERATIONS TEAM

- Kraken Robotics operations team: 5 – 6 maximum
- ROV support team
- Survey team

LAUNCH & RECOVERY

Vessel dependent but generally via the vessel crane or A-Frame along with semi-custom Kraken Robotics supplied launch and recovery aids.

OPERATING SPECIFICATIONS

- Max seafloor inclination 5 degrees
- Max subsea current 0.5 kts - 1.0 kts
- Requires 440 VAC, 3-Phase, 50/60 Hz, 63 A
- Ambient subsea noise threshold applies
- Maximum operating depth: 1500 m

